



# CX

## PNEUMATIC POSITIVE CALIPER



- ✓ Modularity
- ✓ Flexibility
- ✓ High reliability and sensibility with low torques
- ✓ Reduced torque version for highest sensibility
- ✓ Respect for the environment
- ✓ Easy installation

CX Combiflex calipers are particularly designed for applications that require low or medium braking force.

The special characteristic of this system is its modularity: one or more calipers can be installed on brake discs PX with different dimensions obtaining the perfect solution for every requirement.

Moreover, each caliper can be activated or deactivated depending on the required torque, giving maximum flexibility when using different kind of materials.

All calipers are provided with absolute asbestos free pads to safeguard the operator's health and the working environment.

CX calipers are also available with 10%, 16% and 40% reduced torque for those applications that require highest sensibility in terms of braking and where the required torque is very low. The percentage value indicates the braking force in comparison with the standard caliper.

Moreover, depending on the disc, they can be provided with different kind of brackets for an easy, quick and perfect installation.

# TECHNICAL DRAWING

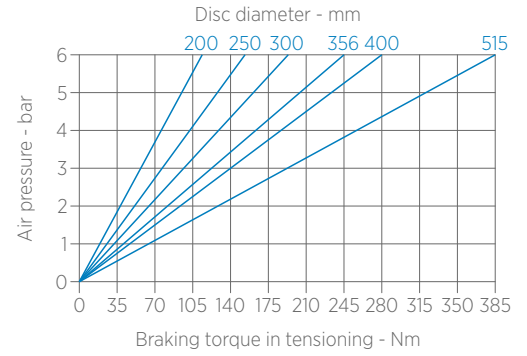
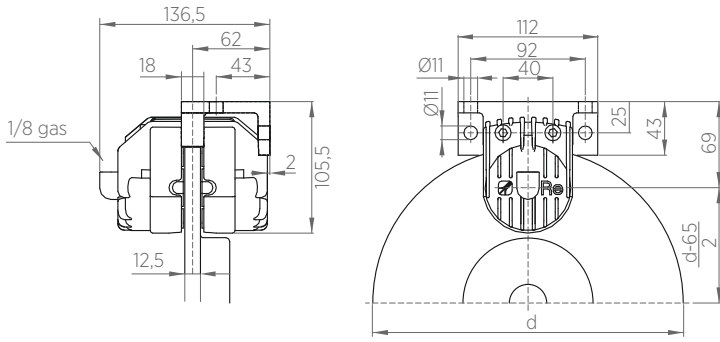

**CX reduced caliper 10% (yellow)**

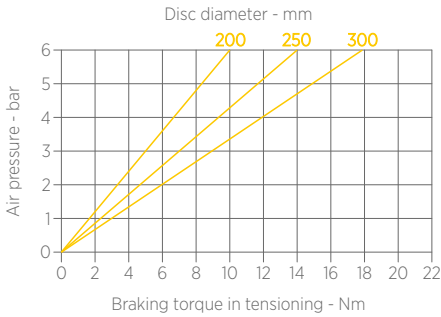

**CX reduced caliper 16% (blue)**

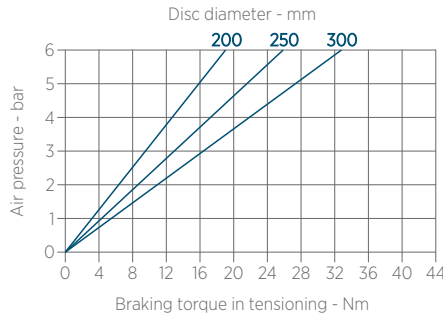

**CX reduced caliper 40% (red)**

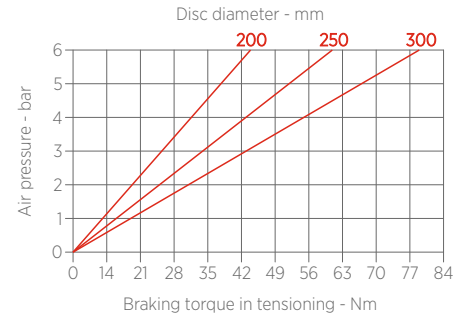

# TECHNICAL CHARACTERISTICS

Tangential force (F) at 6 bar

|                     |            |
|---------------------|------------|
| Standard caliper    | max 1682 N |
| 10% reduced caliper | 153 N      |
| 16% reduced caliper | 286 N      |
| 40% reduced caliper | 675 N      |

Max pressure

6 bar

Pad center (Mp)

0,065 m

\*Data are subject to technical change without notice



Re S.p.A.  
via Firenze 3  
20060 Bussero (MI) Italy

T +39 02 9524301  
F +39 02 95038986  
E [info@re-spa.com](mailto:info@re-spa.com)

Assistenza tecnica  
Technical support  
T +39 02 952430.300  
E [support@re-spa.com](mailto:support@re-spa.com)

Assistenza commerciale  
Sales support  
T +39 02 952430.200  
E [sales@re-spa.com](mailto:sales@re-spa.com)